

SEZIONE A-A

USCITA ARIA REFRIGERATA
TREADED AIR DISCHARGE
ZULUFTAUSGANG
SORTIE AIR GLACEE
SALIDA AIRE ENFRIDA

| | I | GB | D | F | E |
|-------------------|--|--|--|--|--|
| ICW Ø 1 1/4" G | INGRESSO ACQUA REFRIGERATA | CHILLER WATER INLET | KALTWASSEREINGANG | ENTREE EAU GLACEE | ENTRADA AGUA ENFRIADA |
| UCW Ø 1 1/4" G | USCITA ACQUA REFRIGERATA | CHILLER WATER OUTLET | KALTWASSERRAUSGANG | SORTIE EAU GLACEE | SALIDA AGUA ENFRIADA |
| IHW Ø 3/4" G | INGRESSO ACQUA CALDA | HOT WATER INLET | WARMWASSEREINGANG | ENTREE EAU CHAUDE | ENTRADA AGUA CALIENTE |
| UHW Ø 3/4" G | USCITA ACQUA CALDA | HOT WATER OUTLET | WARMWASSERRAUSGANG | SORTIE EAU CHAUDE | SALIDA AGUA CALIENTE |
| IP | INGRESSO CAVO DI ALIMENTAZIONE | POWER SUPPLY CABLE INLET | SPEISEKABELINGANG | ENTREE CABLAGE D'ALIMENTATION | ENTREE CABLAGE ALIMENTATION |
| IS | INGRESSO USCITA SEGNALI | SIGNALS INLET / OUTLET | EINGANG / AUSGANG SIGNALE | ENTREE / SORTIE SIGNALES | ENTRADA / SALIDA SINALIZACIONES |
| IR | INGRESSO RETE | NETWORK INLET | NETWORKEINGANG | ENTREE RESEAU | ENTRADA RED |
| F Ø 6 | INGRESSO ACQUA UMIDIFICATORE | HUMIDIFIER WATER INLET | WASSEREINGANG BEFEUCHTER | ENTREE EAU HUMIDIFICATEUR | ENTRADA AGUA HUMECTADOR |
| C-D Ø 32 | SCARICO ACQUA UMIDIFICATORE E/O CONDENSA | HUMIDIFIER / CONDENSATE DRAIN CONNECTION | KONDENSAT - BZB. BEFEUCHTERABFLUSS | DECHARGE EAU HUMIDIFICATEUR ET/OU CONDENSEUR | DESCARGA AGUA HUMECTADOR Y/O CONDENSADOR |
| AR Ø 100 | INGRESSO ARIA DI RINNOVO | FRESH AIR INLET | FRISHLUFTEINGANG | ENTREE AIR NEUF | ENTRADA AIRE DE RENOVO |
| G1 - G2 | LINEA GAS (USCITA) | REFRIGERANT GAS CONNECTION | HEIGASANSCHLUS | LIGNE GAS (SORTIE) | LINEA GAS (SALIDA) |
| L1 - L2 | LINEA LIQUIDO (INGRESSO) | REFRIGERANT LIQUID CONNECTION | FLUSSIGKEIT - SANSCHLUS | LIGNE LIQUIDE (ENTREE) | LINEA LIQUIDO (ENTRADA) |
| GAS R407C-R22 | ØG1 - ØG2 = 1" - 12UNF ODS 16 (MOD. 0722-0922-1022) ØG2 = 1"1/4 - 12 UNF ODS 22 (MOD. 0721-0921-1021) | | ØL1 - ØL2 = 1" - 12UNF ODS 16 (MOD. 0721-0921-1021-0722-0922-1022) | | |
| GAS R410A | ØG1 - ØG2 = ODM 16 (MOD. 0722-0922-1022) ØG2 = ODM 22 (MOD. 0721-0921-1021) | | ØL1 - ØL2 = ODM 16 (MOD. 0721-0921-1021-0722-0922-1022) | | |

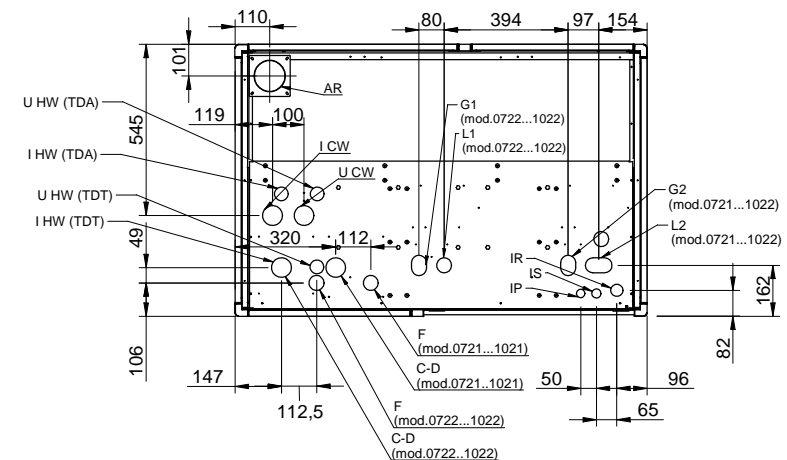

| | | | | | |
|--|--|---|---|---|---------------|
| B Inserito dimensioni attacchi per R410A | | M.Chiodetto | 09/08/08 | | |
| REV. | Descrizione - Description | Disegnatore - Draftsman | Data - Date | Visto - Checked by | n' Com. |
| Materiale - Material | | Trattamento - Treatment | | Rif. Com. | |
| | | Denominazione-Denomination DISSEGNO DI INSTALLAZIONE INSTALLATION DRAWING | | Series TDA/TDT Modello-Model 0721...1022 | |
| Scala-Scale | QUOTE SENZA INDICAZIONE DI TOLLERANZA Grado di precisione medio UNI EN 22768-1(1996) | Dis.-Draftsman A.Miotto Visto-Checked by | Foglio Sheet N. 1/1 Data-Date 13/10/2005 | Disegno-Drawing DICI868X2A | REV. B |